

INDUCTION - 23" SHOEBOX Parking Light Fixtures

100,000 Hrs Life

The Next Generation of Lighting



6" SIDE
ARM



Circular Induction Lamp
Inside



6" WALL
MOUNT

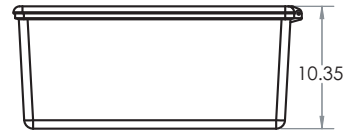
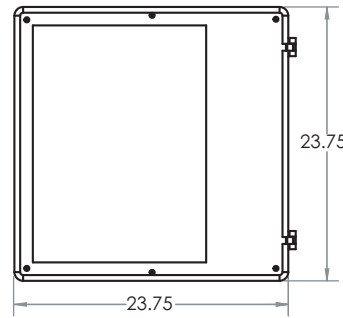

Specification:

- Ballast Type	Electronic
- Start Method	InstantON
- Hot Re-start	InstantON
- Universal Input Line Voltage	120-277 VAC
- Input Line Frequency	50/60 Hz
- Lamp / Ballast System Life	100,000 Hrs.
- Lumen Maintenance @75,000Hrs	> 70%
- Color Temperature	5000°K
- Color Rendering Index (CRI)	83
- Minimum Starting Temperature	-20°F
- Maximum Operating Temperature	160°F
- Lamp Operating Frequency	250 kHz
- Power Factor	> 0.98
- Total Harmonic Distortion	< 10%
- Inrush Current Peak	< 10 Amp
- ETL Listed / UL Standard 1598	Yes
- FCC Compliance	Part 18, Subp. C

Applications, Features, and Benefits

- Housing made of heavy gauge die cast aluminum
- Corrosion resistant electrocoat dark bronze finish
- Custom designed anodized aluminum reflectors for superior illuminance
- Heat and impact resistant tempered flat glass lens. (IESNA full-cutoff)
- Ballast made of long life components
- InstantON(TM) flicker-free Cold Start and Hot Re-Start
- Correlated Color Temperature of 5000°K for greater visibility
- High Power Factor, Low THD Replaceable Ballast
- Advanced phosphors for high Lumen Maintenance and high lumen output
- Up to 20 years Maintenance free operation
- IP 65 Rated for wet locations
- EPA Rating = 1.67
- Mounting Standard: Side Arm (SA6), Wall Mount (WA6), Round Pole Adapter (SA6R)
- Light Sensor Detector (LD) - optional
- Motion Sensor Detector (MD) - optional
- 10 Year Warranty

Product Information

Item No.	Description/Model	Watts	Initial Lumens	Line Voltage Supply	Line Current	Total Harmonic Distortion (THD)	Power Factor	Packaging Dimensions		
								Width	Length	Height
37200	23" SHOEBOX Fixture	200	16,000	120-277 VAC	1.70-0.75 Amp	<10%	0.98	28 in. 712 mm	24 in. 610 mm	12 in. 304 mm
37250	23" SHOEBOX Fixture	250	20,000	120-277 VAC	2.18-0.94 Amp	<10%	0.98	28 in. 712 mm	24 in. 610 mm	12 in. 304 mm
37300	23" SHOEBOX Fixture	300	24,000	120-277 VAC	2.62-1.13 Amp	<10%	0.98	28 in. 712 mm	24 in. 610 mm	12 in. 304 mm
37400	23" SHOEBOX Fixture	400	32,000	120-277 VAC	3.50-1.51 Amp	<10%	0.98	28 in. 712 mm	24 in. 610 mm	12 in. 304 mm
37500	23" SHOEBOX Fixture	500	40,000	120-277 VAC	4.37-1.89 Amp	<10%	0.98	28 in. 712 mm	24 in. 610 mm	12 in. 304 mm

Ordering Information

(SAMPLE NUMBER : 37250-UNV-SA6-LD-120V-BRZ)

Fixture Weight = 50-65 lbs.
EPA Rating = 1.67

Series
37 = 23" Shoebox

Wattage
200 = 200W
250 = 250W
300 = 300W
400 = 400W
500 = 500W

Voltage
UNV = Universal
480 = 480V

Mount
SA6 = 6" Side Arm
SA12 = 12" Side Arm
WM6 = 6" Wall Mount
WM12 = 12" Wall Mount
SA6R = 6" Round Pole Adapter
SA12R = 12" Round Pole Adapter

Accessories
LD = Light Sensor / Photocell
* must verify operating voltage
MD = Motion Sensor

Color
BRZ = Dark Bronze
* custom colors available

NEPTUN Light, Inc.
Questions and Comments:
service@neptunlight.com
Toll-Free: 1-888-735-8330

© Copyright 2009
NEPTUN Light, Inc.

NEPTUN
LIGHT®

